



Working with Wood

Dan Foster

Artist Designer: Maker 3rd Year '23



Instagram: @fozmakes
Website: www.woodbydan.co.uk

Email: drumdan01@gmail.com



Hello!

My name is Dan, and I am currently finishing my final year at Cardiff Met Uni on the Artist Designer: Maker course.

In front of you are a couple of pieces of furniture that aim to showcase my skillset in carpentry and woodwork and my current skill level. It's very easy to admire a piece of furniture for what it is in its intended and final form, but those who are unfamiliar with carpentry as a practice, won't fully appreciate the efforts, frustrations and joys found within the crafting process.

This book aims to take you through the making process of the two pieces of furniture I have created for this show, with photos.

So please, enjoy this book and the rest of the exhibition.

Credenza

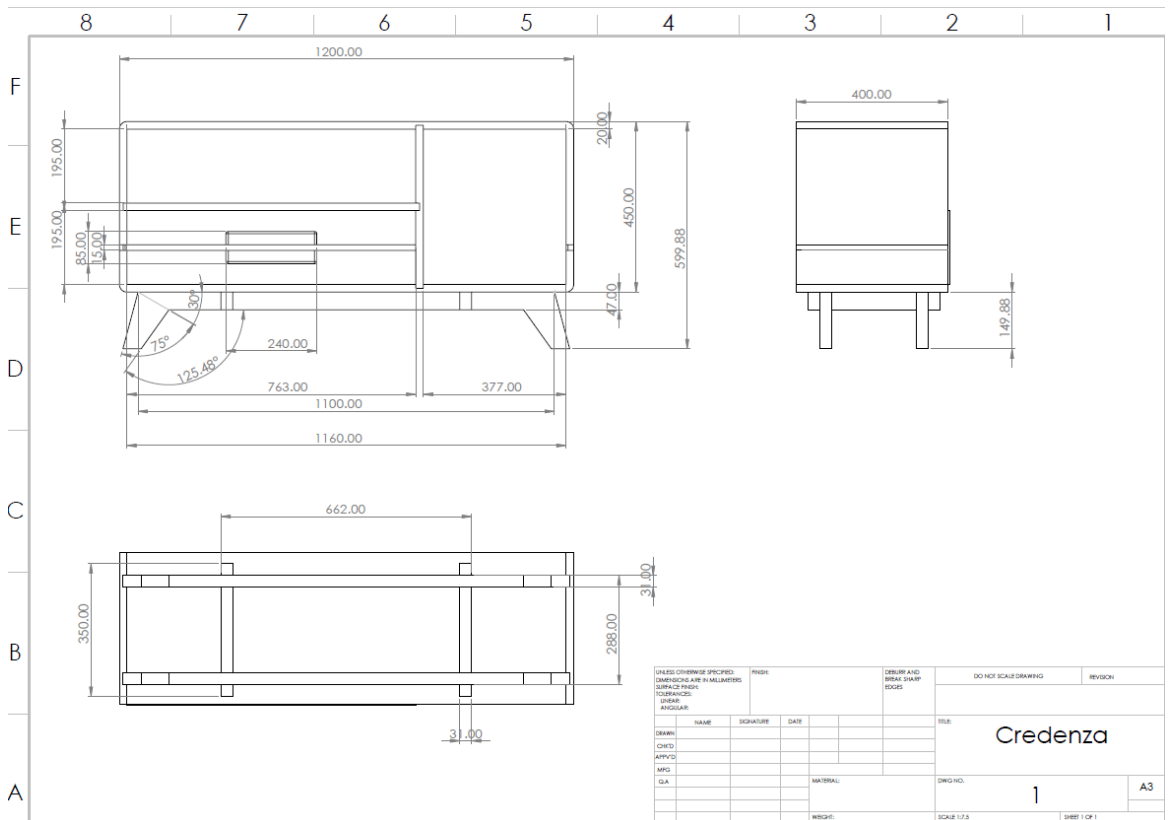
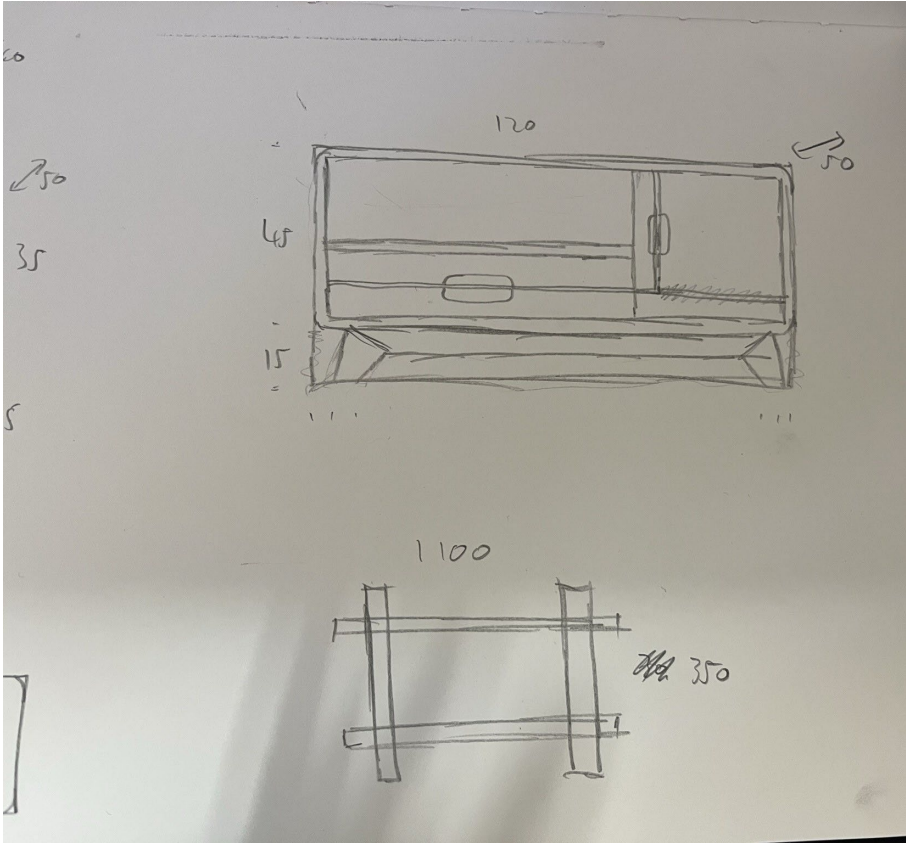



Selecting the wood

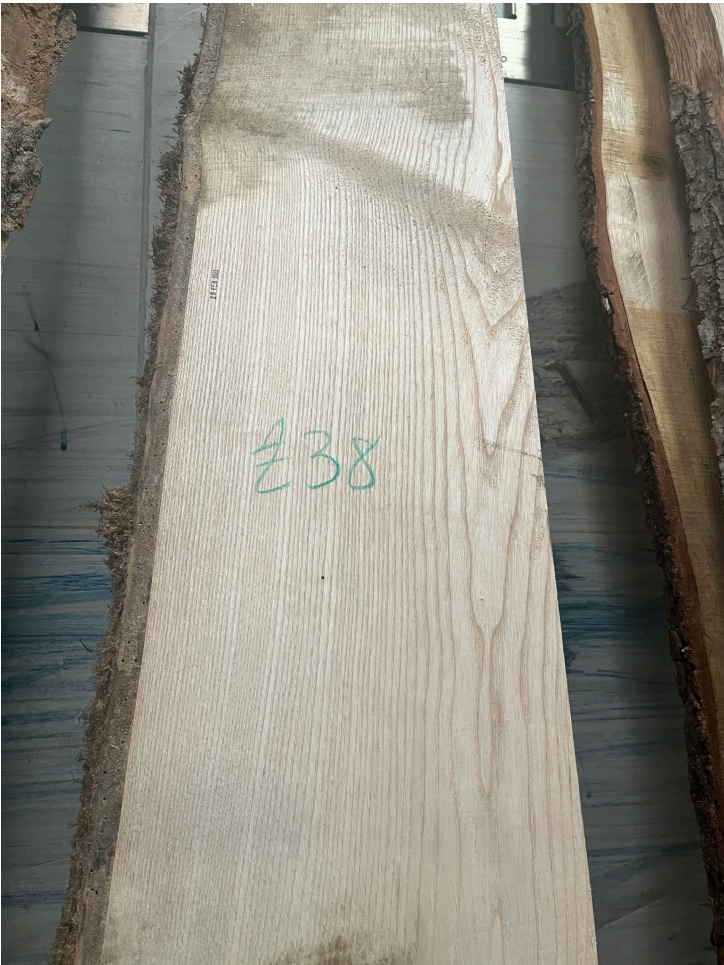





Removing bark and preparing the wood







Planing the wood flat and square









Cutting and sanding the feet





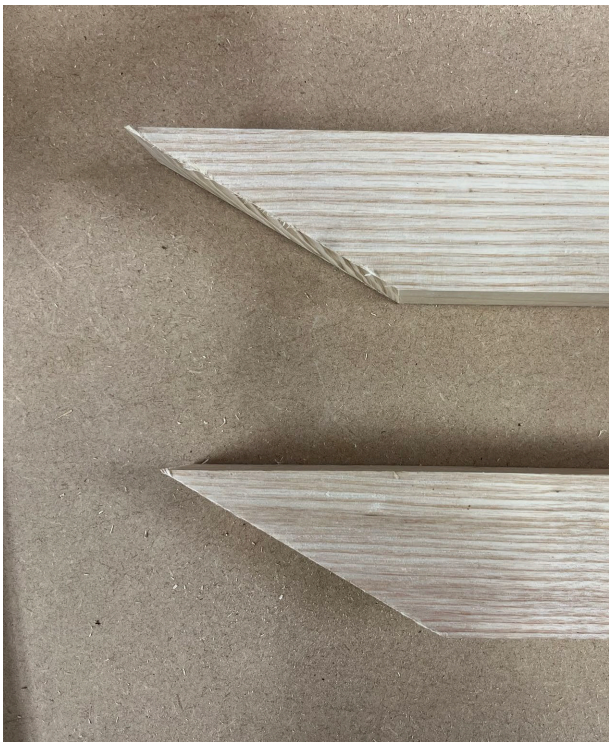
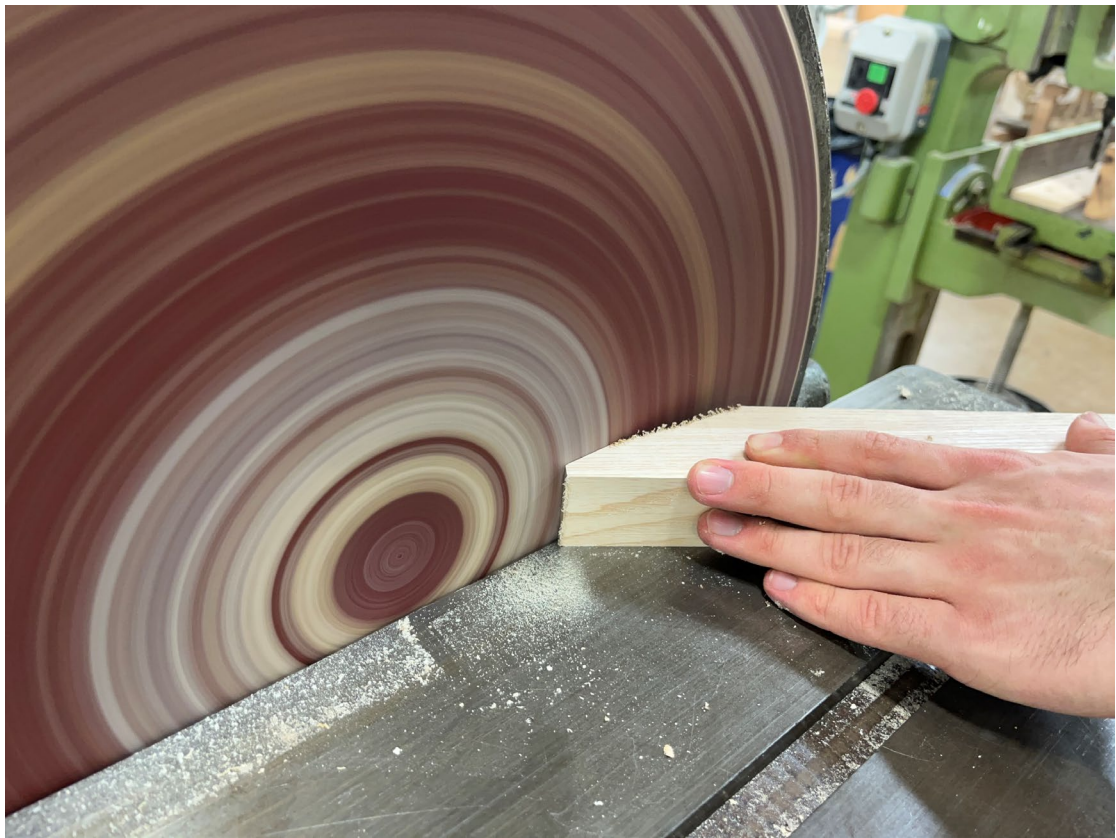



Cutting out the half-lap joints

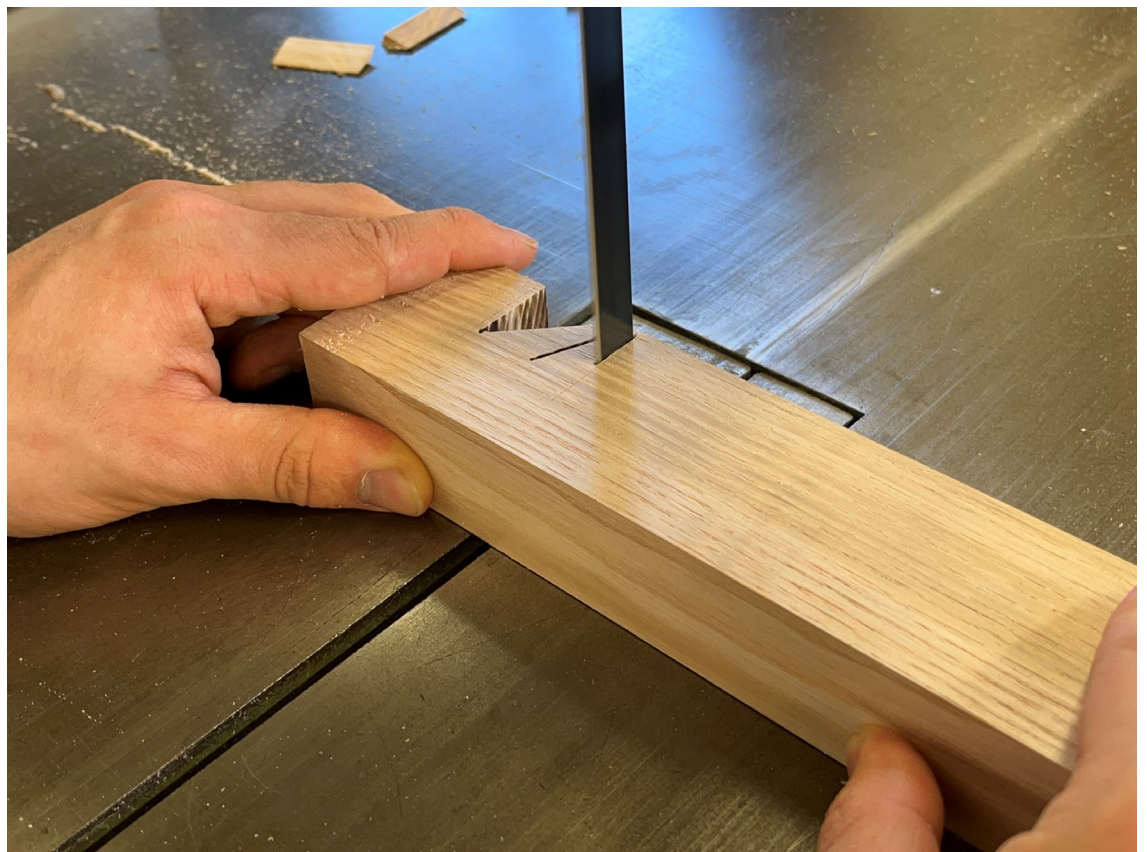





Marking and drilling holes for the dowel pins to use in attaching the feet to the base frame





Gluing the feet







Gluing the frame together



Planing the rest of the Ash timber







Biscuit jointing planks together





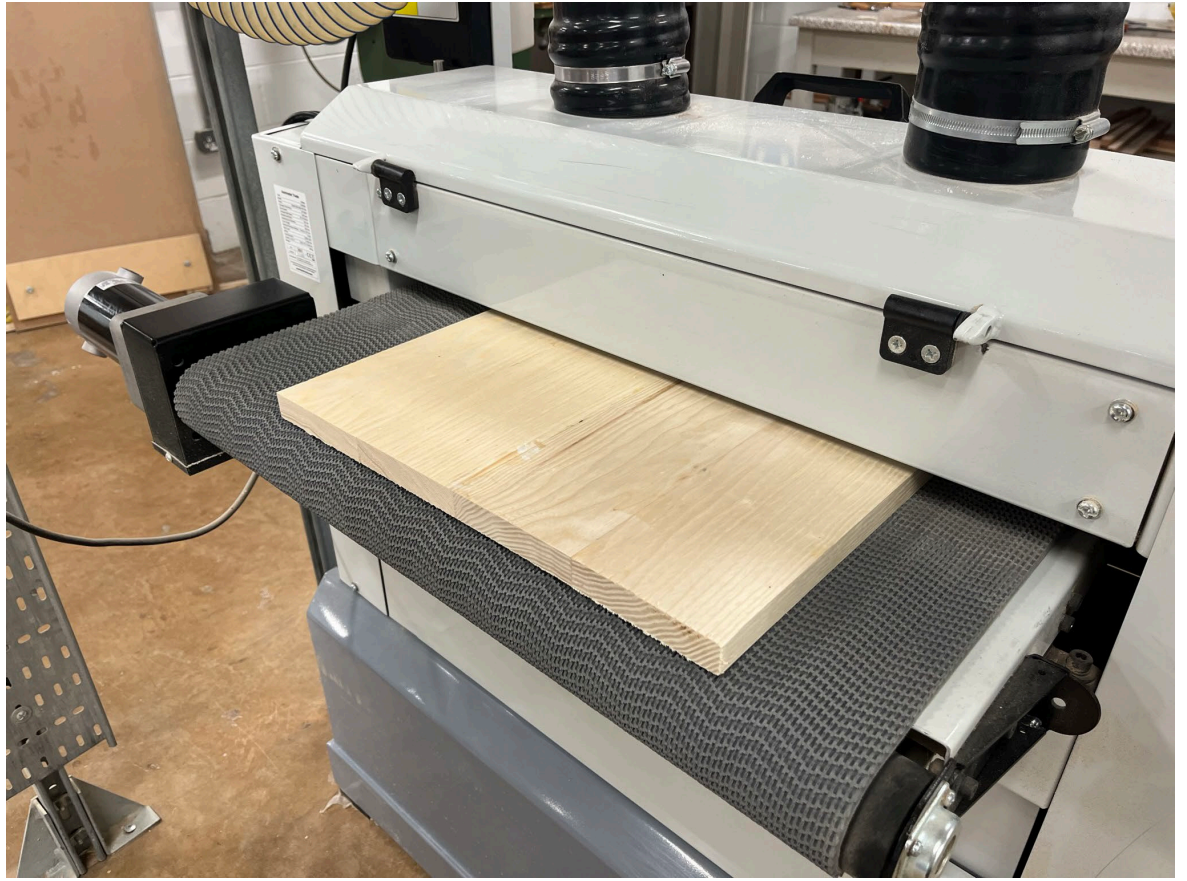

Drum sanding the boards flat





45° mitre cutting







Routing out grooves for inner partitions and walnut details







Walnut details





Hand planing corners and dry fitting



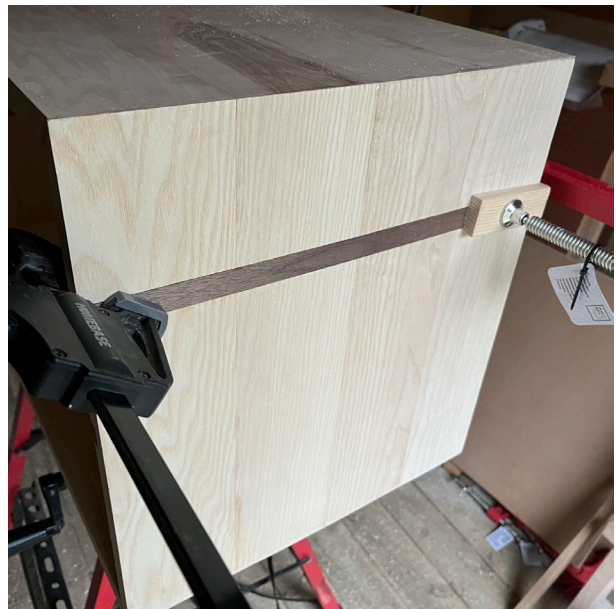

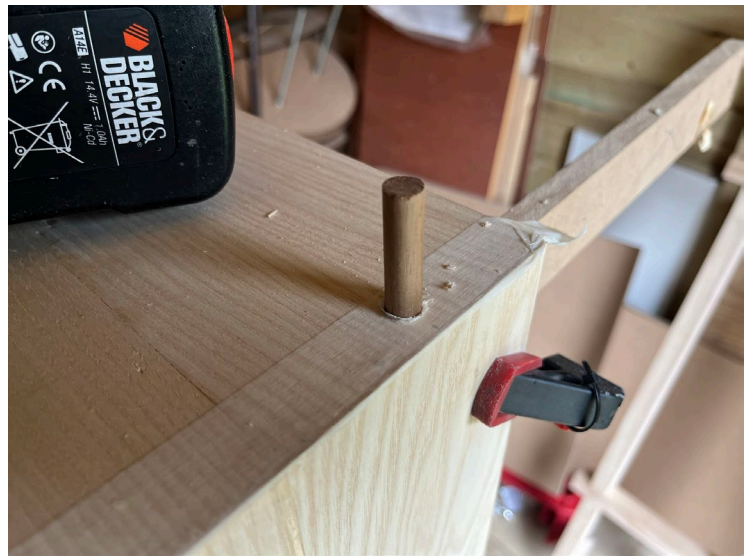

Dowel drilling and pinning for mitre joints



Routing a chamfered edge









Marking out and routing drawer details



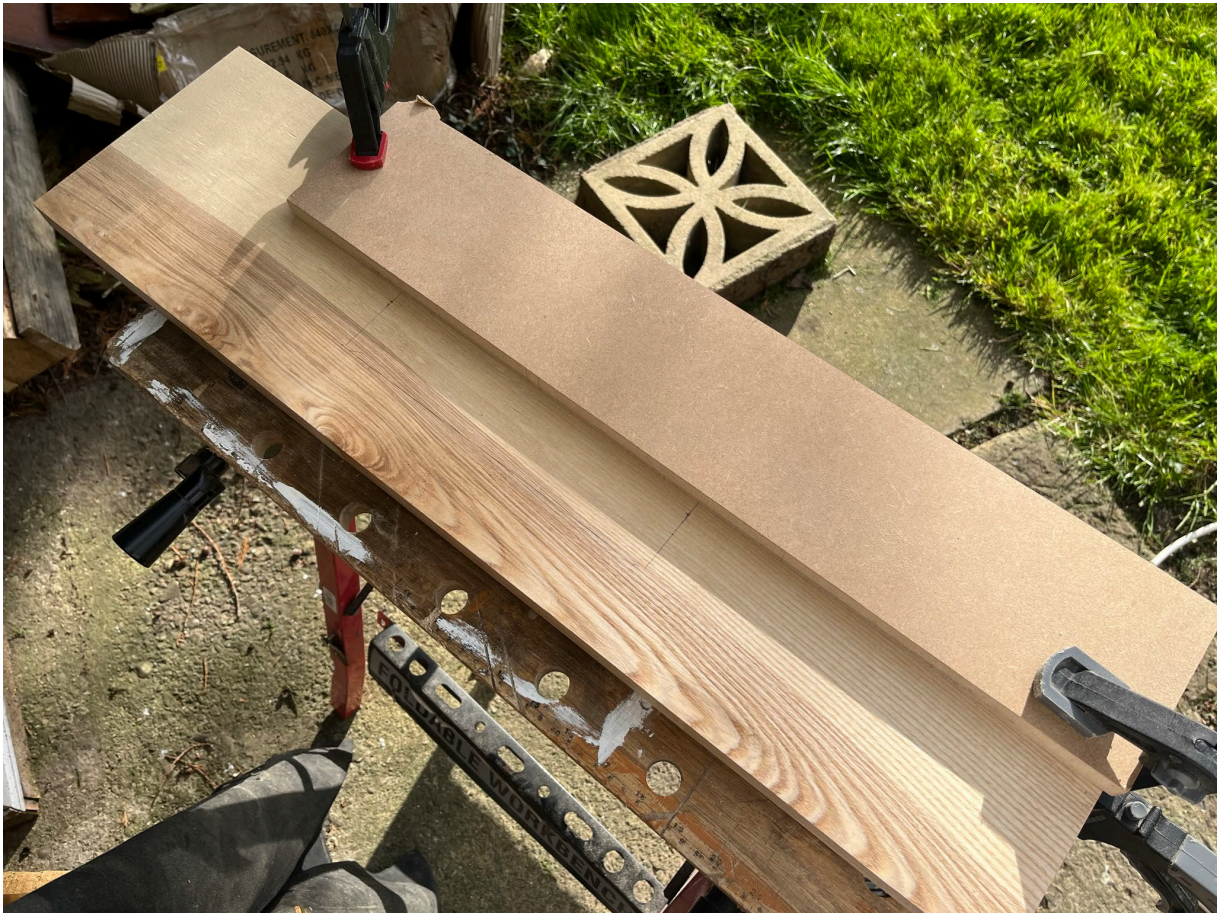



Dish-shaped routed-out drawer recess





Finger grip detail



Drawer bottom slot



Cutting out drawer bottom

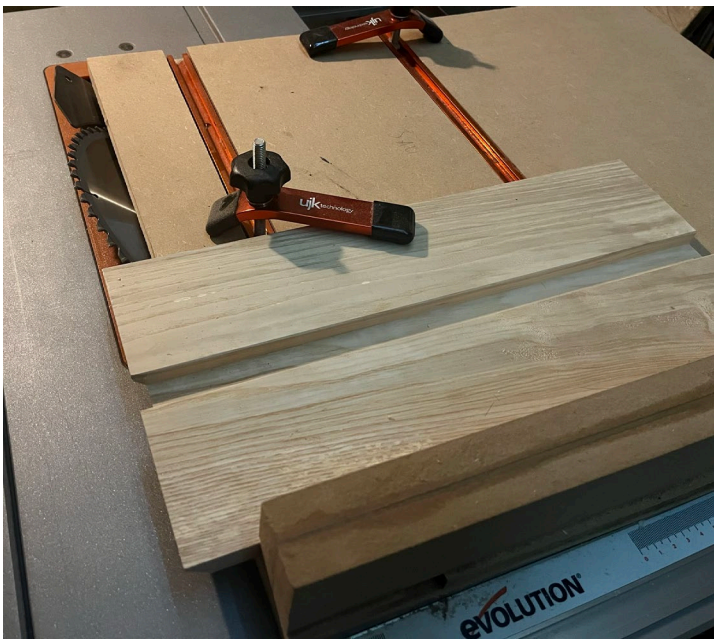



Dovetail joint marking and cutting









Half-blind dovetail joint



Mitre joint for drawer back and slot cut for drawer runners





Complete but unfinished drawer

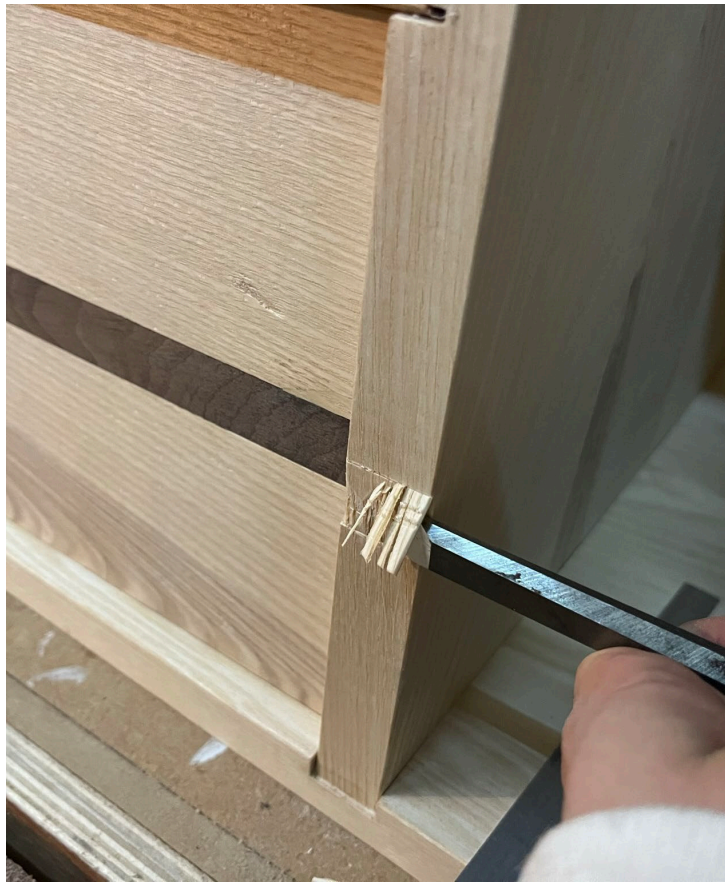

Walnut detail







Fixing the drawer runners

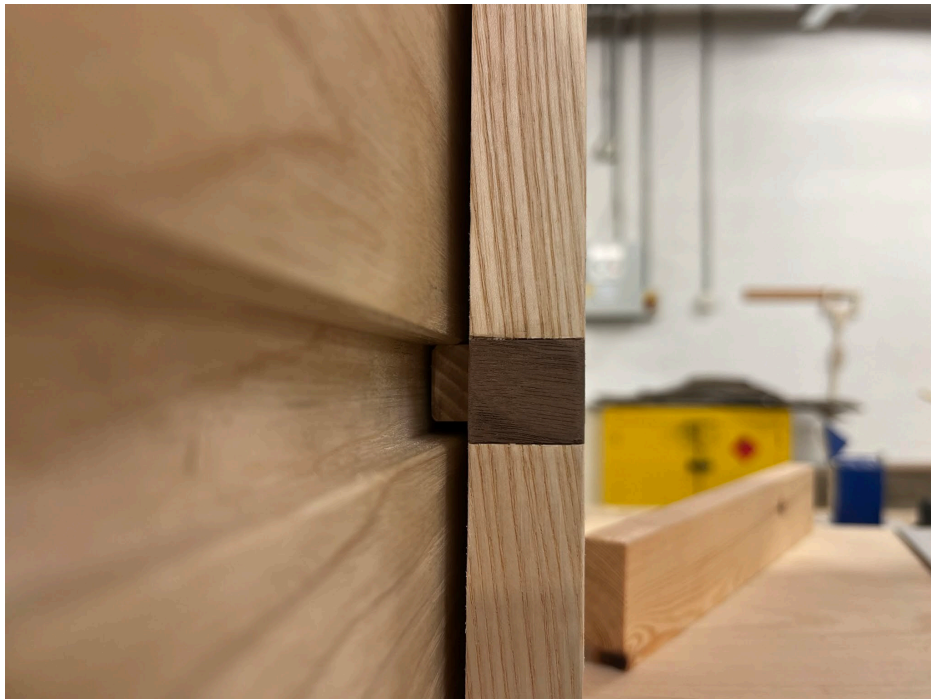
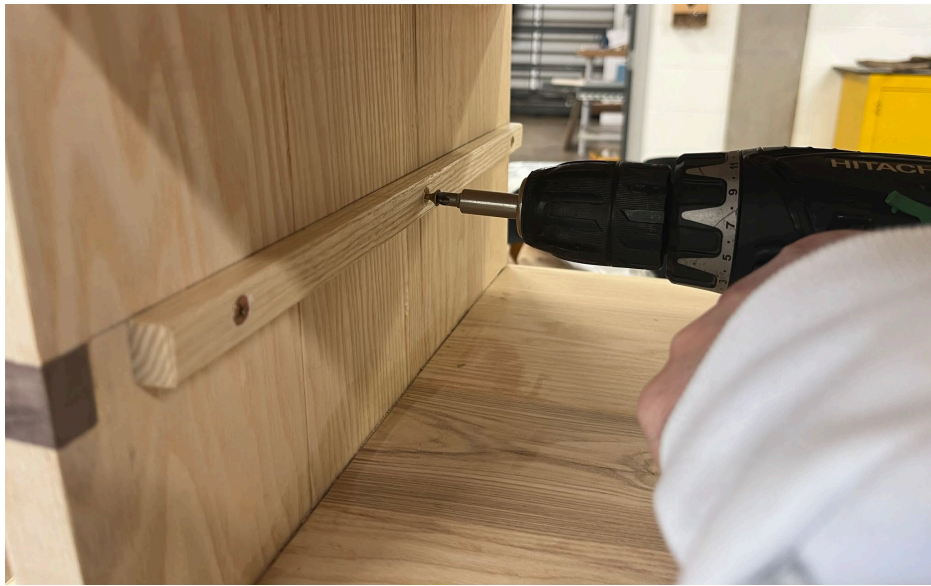





Fitting the base frame





Dowel pin detail



Chosen finishing product (With on right, without on left)













Bedside

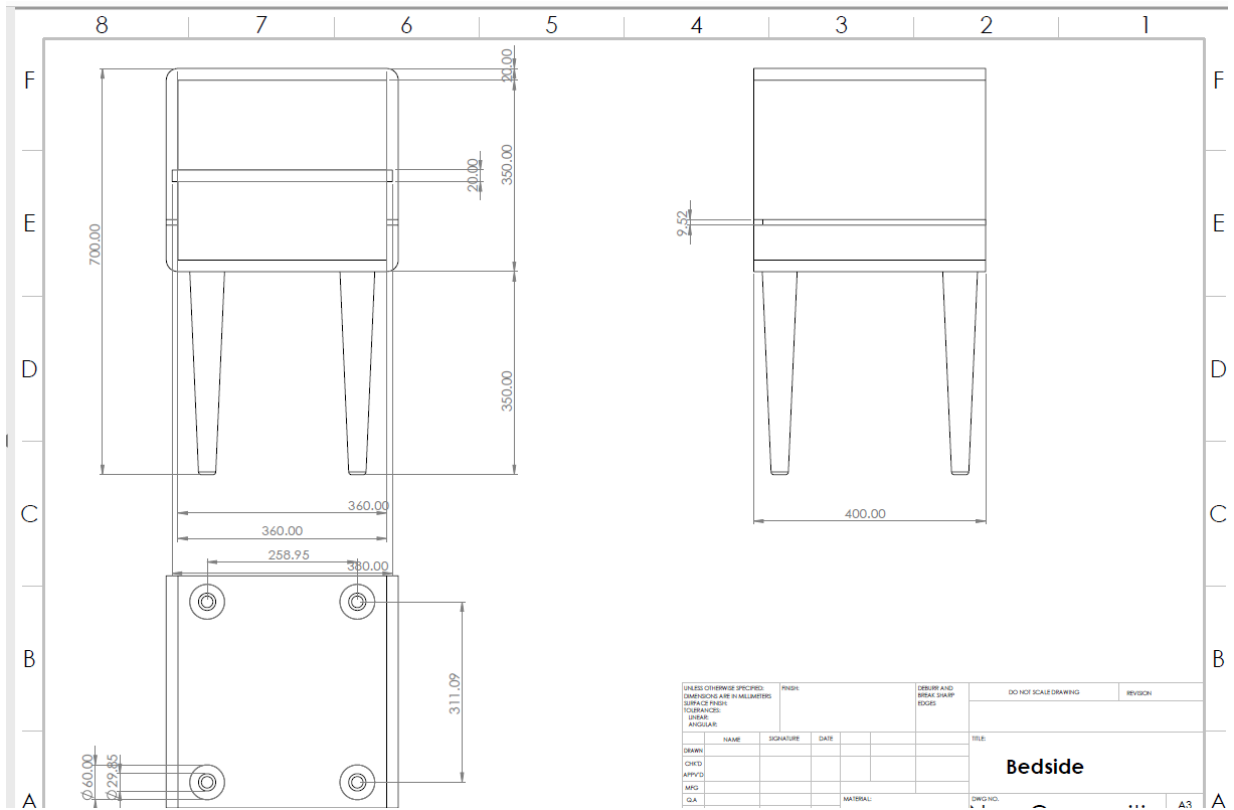
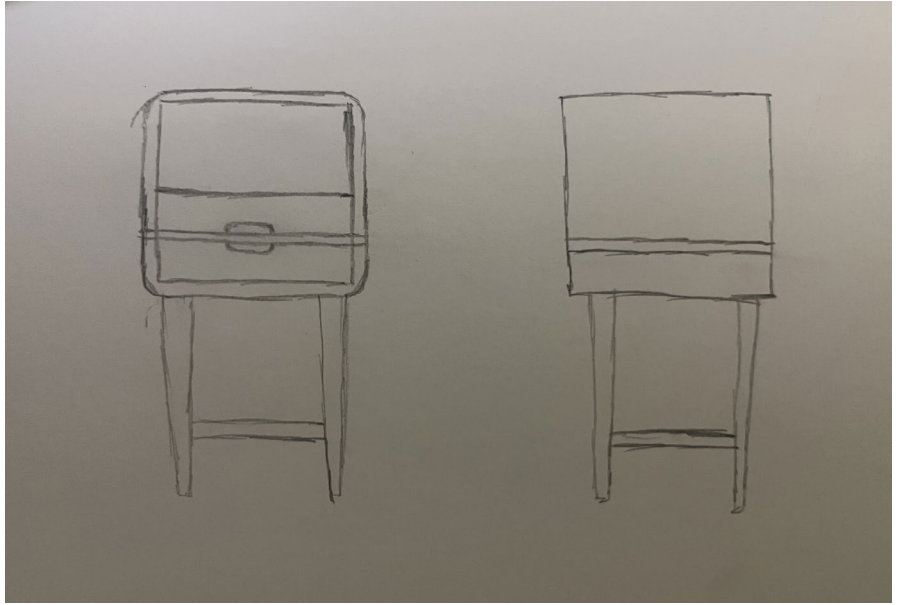
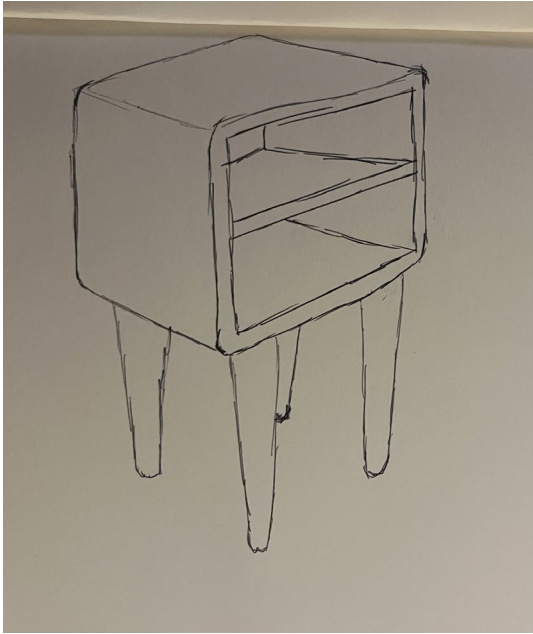





Cutting batons for the legs



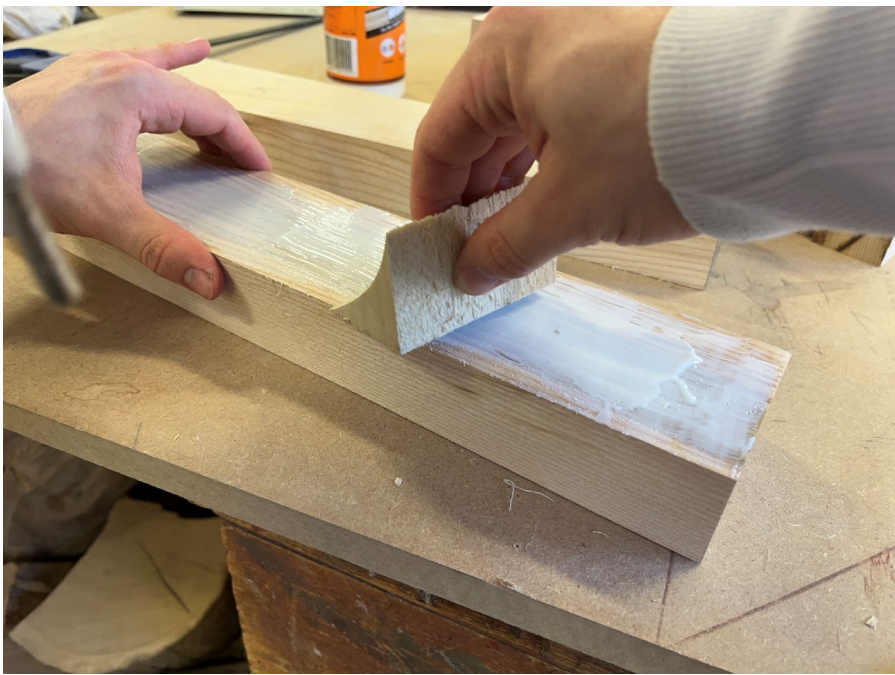



Trimming corners off with self-made jig





Cutting tapers

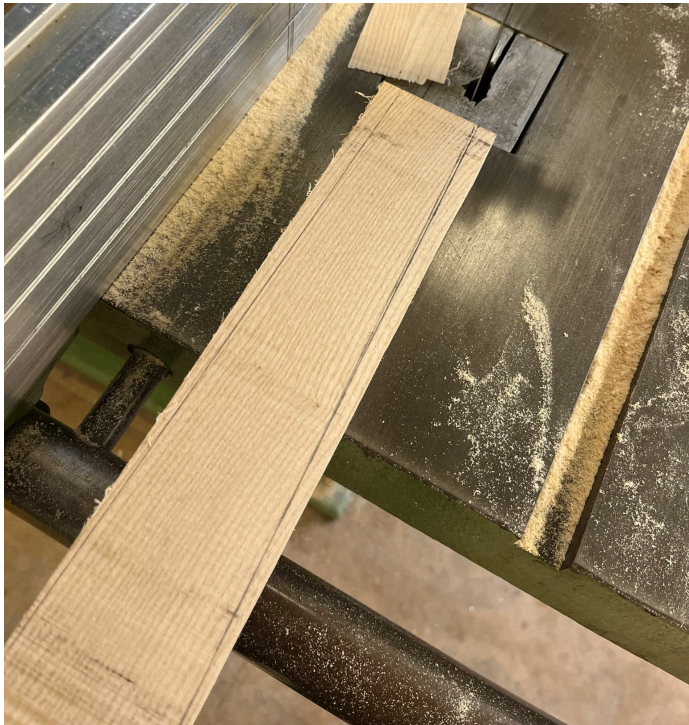

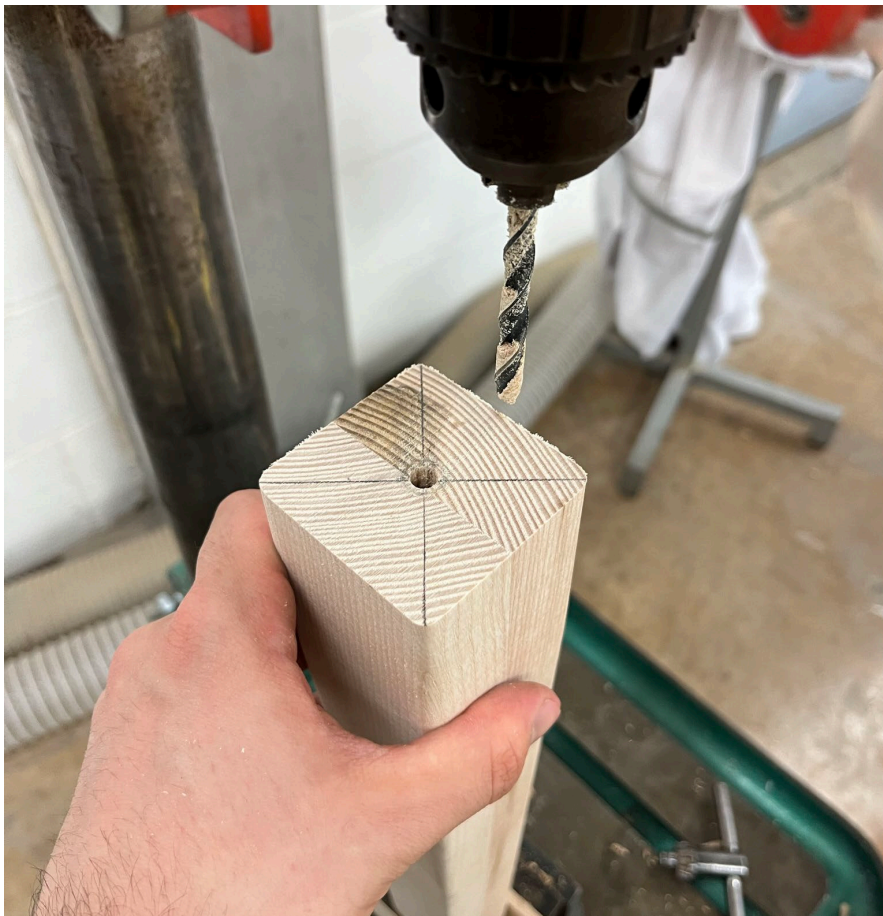

Drilling holes and fitting threaded bolts





Planing Walnut timber









Ready to biscuit joint

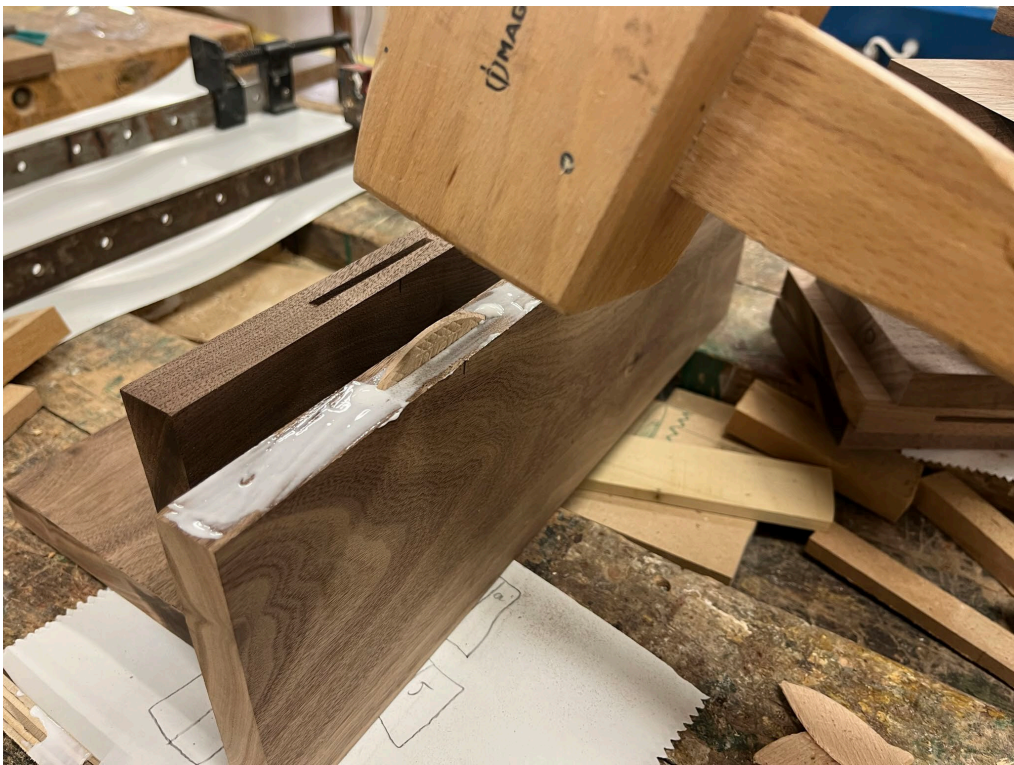

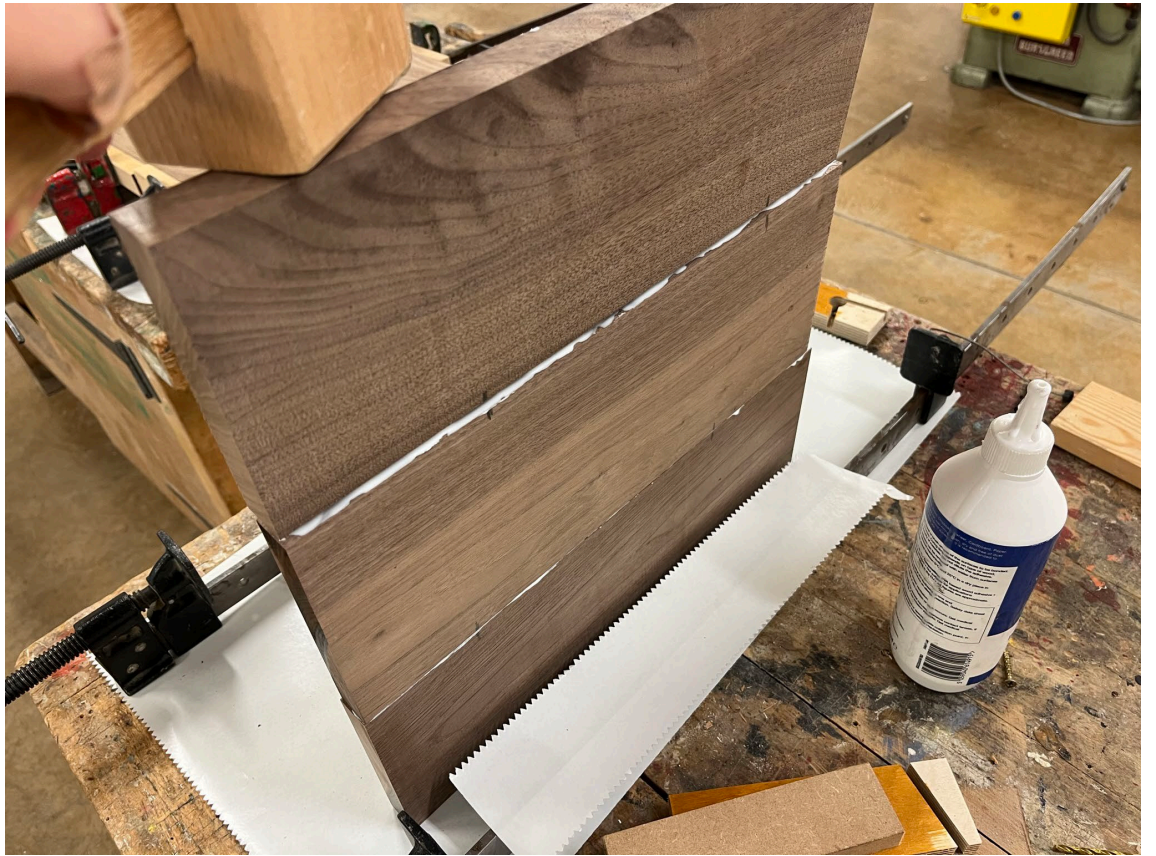



Drum sanding flat and gluing up

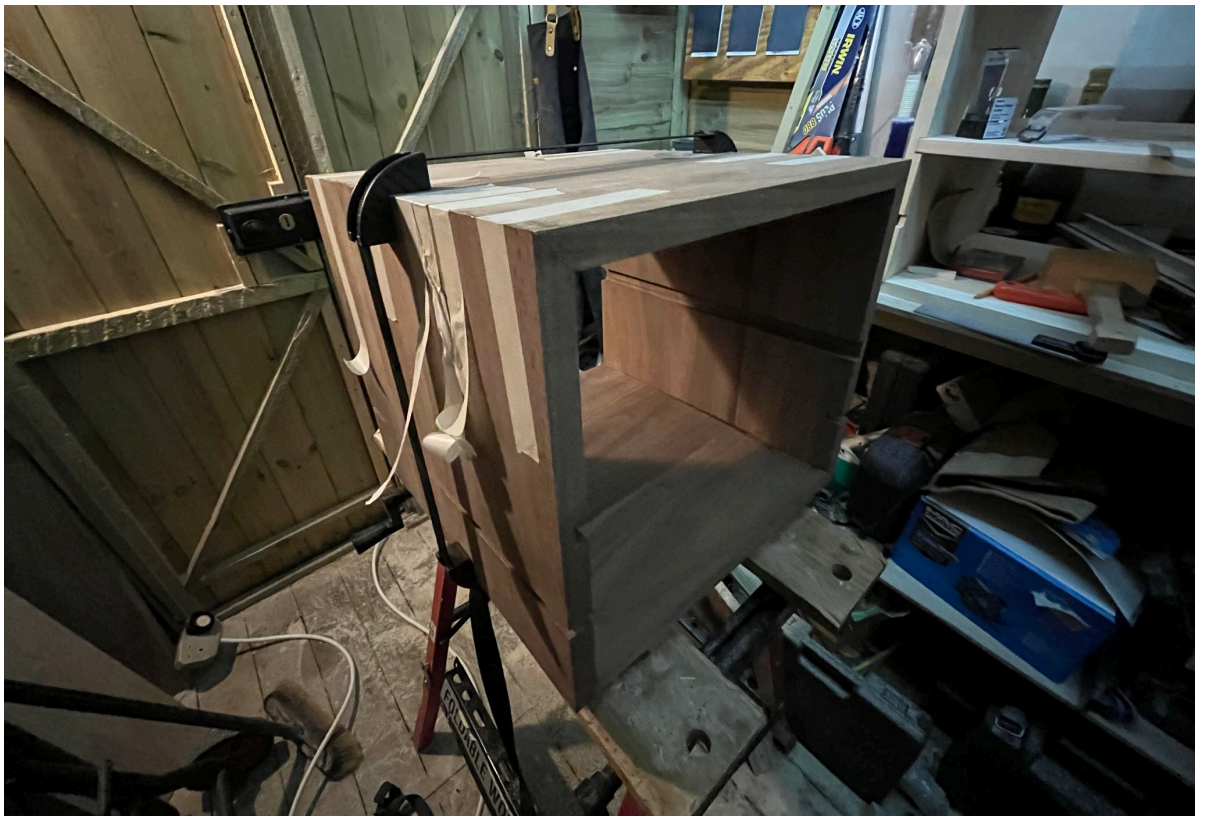

(45° cut off camera)



Routed out slots for brass details and partition





Ash dowel pins





Unfinished carcass



Threaded inserts for legs







Cutting brass bar





Finishing a brushed finish and put into place

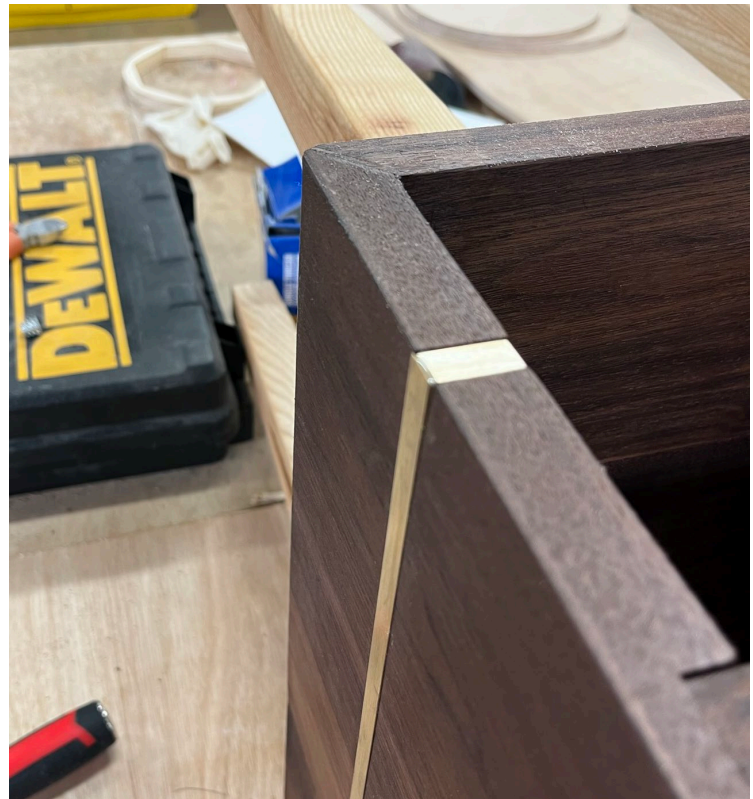









Also on display



Puzzle Box







Walnut and beaten Copper bowl





Walnut and brushed Copper bowl





Ash bowl with stainless-steel base





Plywood bowl with aluminium-inlay strip



